

Safety Precautions

- Read all safety precautions and installation instructions carefully before installing or servicing this fixture. Failure to comply with these instructions could result in potentially fatal electric shock and/or property damage.
 - It is recommended that a qualified electrician perform all wiring. This fixture must be wired in accordance with all national and local electrical codes.
 - Do not handle any energized fixture or attempt to energize any fixture with wet hands or while standing on a wet or damp surface or in water.
 - This fixture is designed for use in a 120-277VAC / 60Hz circuit. This fixture is compatible with a TRIAC (forward-phase or leading-edge) / ELV (reverse-phase or trailing-edge) or 0-10V dimmers.
 - Make sure that the power source conforms to the requirements of the fixture. (See labels on the fixture housing).
 - To reduce the risk of electrical shock, and to assure proper operation, this fixture must be adequately grounded. To accomplish proper grounding, there must be a separate ground wire (green) contact between this fixture and the ground connection of your main power supply panel.
 - This fixture is intended to be used for general indoor lighting in dry, damp, or wet locations. For wet locations, fixture must be mounted at least 48 inches above ground level.
 - Disclaimer
 Changes or modifications not expressly approved by the party responsible for compliance could void the user's authority to operate the equipment. NOTE: This equipment has been tested and found to comply with the limits for a Class B digital device, pursuant to Part 15 of the FCC Rules and Canadian ICES-005 (B) / NMB-005 (B). These limits are designed to provide reasonable protection against harmful interference in a residential installation. This equipment generates, uses and can radiate radio frequency energy and, if not installed and used in accordance with the instructions, may cause harmful interference to radio communications. However, there is no guarantee that interference will not occur in a particular installation. If this equipment does cause harmful interference to radio or television reception, which can be determined by turning the equipment off and on, the user is encouraged to try to correct the interference by one or more of the following measures:
 - Reorient or relocate the receiver antenna.
 - Increase the separation between the equipment and receiver.
 - Connect the equipment into an outlet on a circuit different from that to which the receiver is connected.
 - Consult with the dealer or an experienced radio/TV technician for help.
- Any modifications to this fixture may void the warranty and interfere with the safe operation of the luminaire.
 Operation is subject to the following two conditions: (1) this device may not cause interference, and (2) this device must accept any interference, including interference that may cause undesired operation of the device.
- Please contact AFX Engineering Dep for FCC report at AFX, Inc., 2345 N. Ernie Krueger Circle, Waukegan, IL, USA or Telephone: 1-847-249-5970.

Assembly Instructions

Step 1 – Preparing for installation

- Disconnect electrical power** at fuse or circuit breaker box before installing or servicing any part of this fixture.
- Carefully remove the fixture from the carton, remove components from hardware kit.
- Install the short screws (1) with lock washers (3) and hex nuts (4) (all provided) into the offset holes of the round mounting bracket (2) as shown in Fig 1 & 2. Be sure the two screws (1) line up with holes in canopy (6) and point away from junction box (not provided).
- Install and secure the round mounting bracket assembly to the junction box (not included) using two screws (5) to secure it.

Step 2 – Assembling the fixture

- A center pipe stem is supplied with this fixture consisting of up to three, 12" lg. pipe sections (16) to be connected with pipe nipples (14), supplied. Pre-assemble pipe stem. Using the nut & washers from strain relief (8), attach swivel (15) with nipple (14). Attach (pre-assembled) pipe stem to swivel. Route the power cord (9) through the pipe stem first, before attaching to fixture (Fig 3) above nut & washer (17) & diffuser (18).
- Feed the three aircraft cables (11) to the connectors (12) that are mounted on the pan. Insert the cable by pressing the "Spring Pin" (12) (Fig. 3) downward and holding until it comes out at the other end. Repeat these steps for the other cables. Note: **Cable length adjustments might be needed again for the correct cord length, alignment and be equal to the center pipe stem length.**

Wiring – All wiring must take place inside junction box (not included)

Caution: Make sure power is off at fuse or circuit breaker box. Check power wires for damage or scrapes. If power supply wires are within three inches of the LED driver, use wire suitable for at least 90°C (194°F). **Note:** Most dwellings built before 1985 have supply wire rated to 60°C. Consult a qualified electrician to ensure correct branch circuit conductor before installing.

Step 3 – Wiring fixture

- Make all wire connections to appropriate wire. Secure with wire nuts (provided).
- Connect the green wire from the fixture to the supply power source ground wire.
- For none-dimming fixture.** Connect the white wire from the fixture to the white (N) wire from supply power source. Connect the black fixture wire to the black (L) wire from supply power source. Gray and purple wires are not to be used and must be individually capped to prevent shorting.
- For TRIAC dimming.** Connect the white wire from the fixture to the white (N) wire from dimming source per dimmer wiring instructions. Connect the black wire from the fixture to the black (L) wire from dimmer supply power source per dimmer wiring instructions. Gray and purple wires are not to be used and must be individually capped to prevent shorting.
- For (0-10V) dimming.** Connect the gray wire from the fixture to the dimmer source gray wire. Connect the purple wire from the fixture to the dimmer source purple wire. Connect the white wire from the fixture to the white (N) wire from dimming source per dimmer wiring instructions. Connect the black wire from the fixture to the black (L) wire from dimmer supply power source per dimmer wiring instructions.
- Do not mix wires.** Pull on each wire lead to make sure connections are secure. Make certain no bare wires are exposed outside of wire connectors. Tuck all connections neatly into the junction box. .

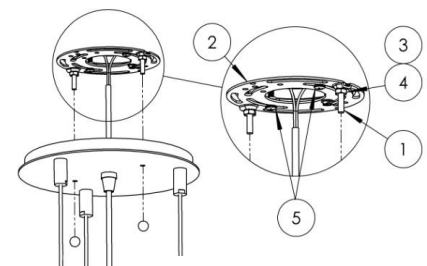

FIG 1

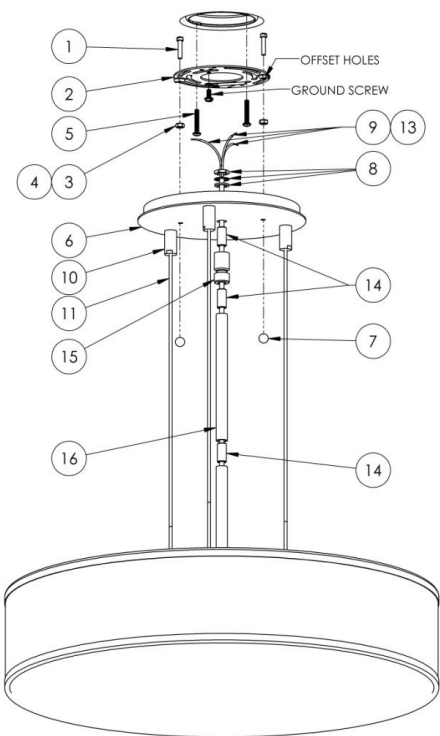

FIG 2

Step 4 – Mounting fixture

- A. Line up the two holes in the canopy (6) with the two screws in the mounting bracket (2). Secure fixture to screws (1) with two thumb nuts (7).

Step 5 – Adjusting fixture height

- A. Adjust the aircraft cables up and down by pressing the “spring pin” (12) downward and holding until the proper cable length is attained based on the center pipe stem length so they are taut and even. Repeat for other two cables. Note: Extra cable length should be looped, tied, or cut to minimize light shadows within the diffuser.

Step 6 – Mounting diffuser (Fig. 3, 4 & 5)

- A. Inner diffuser (18) is assembled with pipe nipple (14), nut & washer (17) and is part of the fixture assembly to be mounted. When fixture is mounted, the outer diffuser sits atop the inner diffuser by 3 hooks as shown in Fig. 4.
- B. Install white lens by inserting it at a slight angle inside the inner diffuser. Level it out with the shade and lower it down. Lens is supported by inner diffuser. Complete diffusers and lens installation as shown in Fig 4 & 5.

Step 7 – Restore power at fuse or circuit breaker box

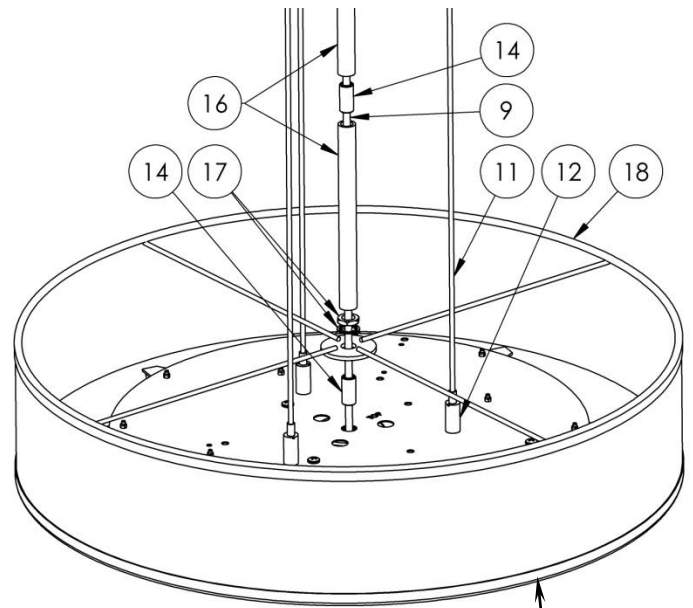

FIG 3

For your information: This LENS is at the bottom of the foam/packaging so take care that it is not discarded!

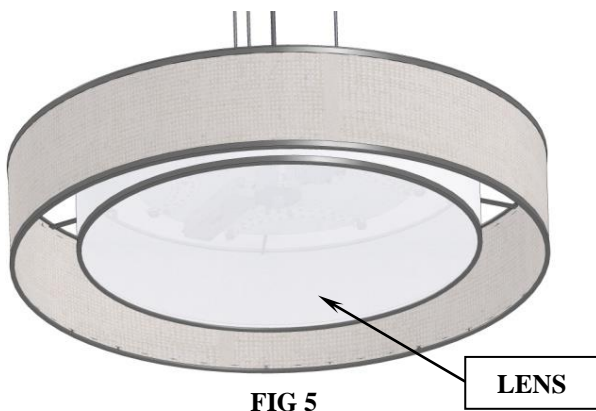

FIG 5

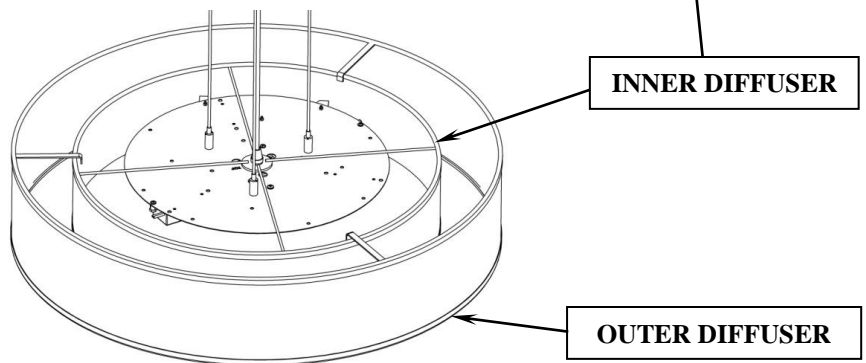

FIG 4

Limited Factory Warranty

This product is manufactured by AFX Inc. AFX Inc. hereby warrants that this fixture is free from defects in materials and workmanship when installed and used under normal operating conditions for a period of 5 years from date of purchase. This warranty covers all component parts and extends only to replacement of defective fixture or components; it does not cover failure due to improper installation, misuse, mishandling or damage incurred in transit.